

**5th INTERNATIONAL CONFERENCE
PREDICTIVE MODELLING IN FOODS**

IC PMF 2007

Fundamentals, State of the Art and New Horizons

September 16-19, 2007

ATHENS - GREECE

TRAINING CENTRE OF THE NATIONAL BANK OF GREECE

PROCEEDINGS



Agricultural University
of Athens (AUA)



Aristotle University
of Thessaloniki (AUTH)



National Technical University
of Athens (NTUA)

International co-organisers:



*KU Leuven (Belgium), ADRIA (France),
IFR (UK), University of Tasmania (AU)*

<http://pmf2007.chemeng.ntua.gr>

Evolving from high through low uncertainty risk assessments for dairy products using kinetic, stochastic and fault tree modelling

J.H.M. van Lieverloo, M. Fox, M. Schutyser, M.C. te Giffel and P. de Jong

NIZO food research, Kernhemseweg 2, 6718 ZB Ede, the Netherlands (Hein.van.Lieverloo@nizo.nl).

Abstract

A framework was developed to facilitate the process of balancing quality and costs of food production. It is based on NIZO's Premia simulation system to model growth and inactivation of micro-organisms throughout the food chain, supplemented with a stochastic tool (@RISK) and a fault tree analysis tool (Fault Tree +). This allows for quantitative risk assessments to evolve to the level of certainty that is required by the risk manager within one framework. The output quickly shows in what part of the chain risk and variation originate, allowing risk managers and risk assessors to focus on the right priorities for optimisation.

Two case studies are demonstrated, evaluating the risks of *Listeria monocytogenes* contamination of pasteurised milk and contamination of milk used in yogurt production. The results show that risk assessment and risk management for these products should be focussed on contamination as a result of malfunction of either pasteurisation or filling of cartons. However, verification monitoring never shows any contamination. Therefore the Fault Tree Analysis part of the framework is used to acquire estimates of contamination. This results in a shift of attention from monitoring top events (contamination) to quantifying the probability of base events (causes of contamination). The framework will be used to model all product-contamination combinations using readily available data and models, resulting in a priority list for optimisation of risk assessment and risk management.

Keywords: quantitative risk analysis, microbial risk analysis, fault tree analysis, milk, yoghurt

Introduction

Risk managers in the food industry use risk assessment to determine the need and priority of optimisation of production processes, including the efficiency of quality assessment and control, e.g. the monitoring of product quality. Quantitative risk assessments (QRA) are an important part of these risk assessments, but also need to be efficient. Fine-tuning is sufficient once the risk manager accepts the levels of uncertainty and variability in the output. It is, however, hard to predict when this target will be achieved. Therefore, ideally, the same modelling environment is used for both preliminary and in-depth risk assessments. This paper will discuss two cases of preliminary risk assessments built up within such a framework, to show its potential. These cases concern the risk of high levels of the pathogen *Listeria monocytogenes* (FAO/WHO 2004) in (i) pasteurised consumer milk, and (ii) yoghurt produced from pasteurised milk. Both products are known as low-risk products for *L. monocytogenes* and the available growth models are suitable for these matrices.

Materials and methods

Production chains of pasteurised milk and yoghurt

The production processes are presented in Figure 1. Raw milk contamination with *L. monocytogenes* was estimated from unpublished national surveys in The Netherlands. None of the 276 samples of 25 ml contained *L. monocytogenes* and the concentration is estimated at a maximum of 1 Colony Forming Units (CFU) per 6,9 litre = 0,15 CFU/L.

Modelling growth and inactivation of *L. monocytogenes* in the food chain

Modelling starts with available data and general growth and inactivation models, such as the linear Arrhenius-Davey model for pasteurisation (Davey *et al.*, 1995) and the Gamma model (Zwietering *et al.*, 1996) for growth, using the Premia simulation tool (De Jong *et al.*, 2002).

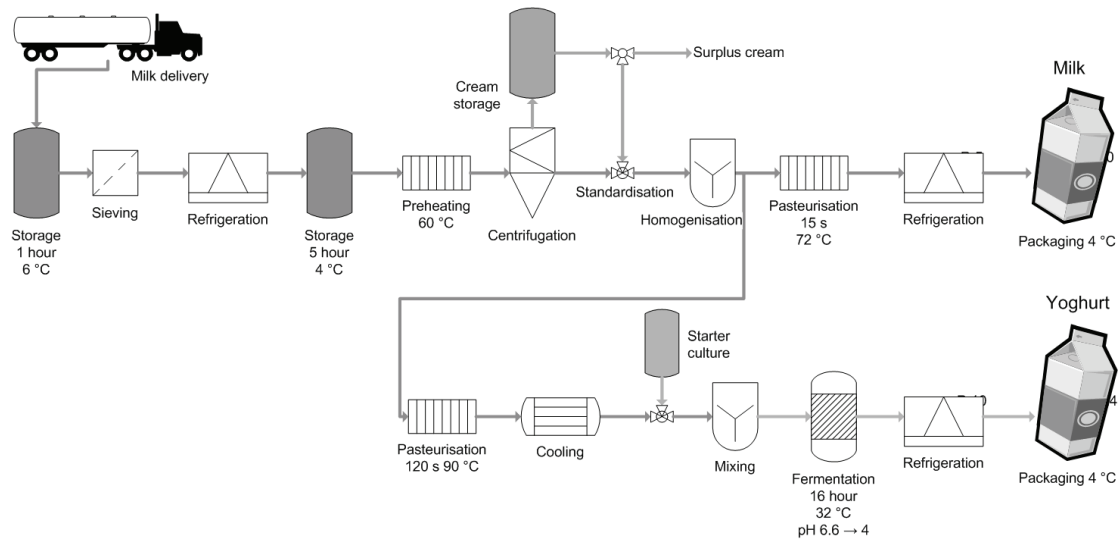

Figure 1: Mean process conditions for pasteurised milk and yogurt production.

Modelling nominal variation

To include variation of process conditions into the model, either empirical or fitted probability density functions (PDFs) of monitored process conditions are used. These PDFs are analysed and fitted using @RISK professional 4.5.5 by Palisade Corporation.

Assumed conditions simulated with Excel and @RISK functions

Concentration in raw milk (CFU/g): RiskGamma(1;1/(277*25)); Pasteurisation of milk: RiskNormal(75;0,51) °C; RiskNormal(15; 1,02) s. Pasteurisation of milk for yoghurt production: RiskNormal(90;1,02) °C; RiskNormal(120; 2,55) s. Yoghurt fermentation: RiskNormal(32;1,02) °C; pH (0-4 h): RiskNormal(6,520973; 0,060781); pH (4-8 h): RiskPert(5,5932; 6,5302; 6,652); pH (8-12 h): RiskBetaGeneral(1,1693; 1,4187; 4,547; 5,8426); pH (12-16 h): RiskWeibull(2,0402; 0,2155; RiskShift(4,21693)). Maximum time to consumption (MTC): 288 h (milk) or 768 h (yoghurt); Storage and transportation (ST): 4 °C; 36 h. Retail (R): MAX(0;RiskNormal(5,5;2,7)) °C; RiskPert(0;36;MTC-ST) h; Transportation to home (CT): RiskPert(4;15;40) °C; RiskPert(0,25;1;16) h; Home refrigerator: MAX(0;RiskNormal(6,5;2,7)) °C (Laguerre *et al.*, 2002). Maximum time in refrigerator (FRIG) = MCT-ST-R-CT (h). Time carton closed: FRIG – time open (h). Time carton open: RiskPert(0;IF(FRIG>96;48;IF(FRIG>48;24;MIN(12;FRIG)));MIN(96;FRIG)).

Modelling contamination event probabilities

Fault tree analysis is used in high impact industries (chemical, atomic, aircraft, military) to predict the extremely low probabilities of unacceptable top events (e.g. explosions) (Vesely *et al.*, 1981). It was used to improve estimates of dairy product contamination probabilities. Fault Tree + by Isograph (Reliability Work Bench 10.0.3) was used to calculate Boolean minimal cut-sets and Monte Carlo PDFs.

Safe level for *Listeria monocytogenes*

The European Community requires that *L. monocytogenes* should be absent in 25 gram samples of dairy products and pasteurised milk and that consumption of foodstuff, which contains over 100 *L. monocytogenes* bacteria per gram, is regarded as a direct risk for human health, whereas concentrations less than 100 bacteria/g are usually not considered significant

for human disease, except in vulnerable population groups (European Food Safety Authority, 2006). Therefore modelling results are compared with these levels.

Results and discussion

Growth and inactivation of L. monocytogenes during milk production

Inactivation of *L. monocytogenes* is 100% under nominal pasteurisation conditions, even when concentrations in the raw milk would have been 100 times higher than the maximum level found now (mean < 0,15 CFU/l). The risk during production therefore originates from a contamination due to malfunction of pasteurisation or packaging. Subsequent variation in growth upon the event of contamination originates from variation of temperatures and variation of the time to consumption (Figure 2). In the very unlikely case a carton is contaminated with 1 CFU during production, the probability is 91% that this carton will contain over 100 CFU per ml at the moment of consumption. If such a contamination occurs at home, this probability is only 3%.

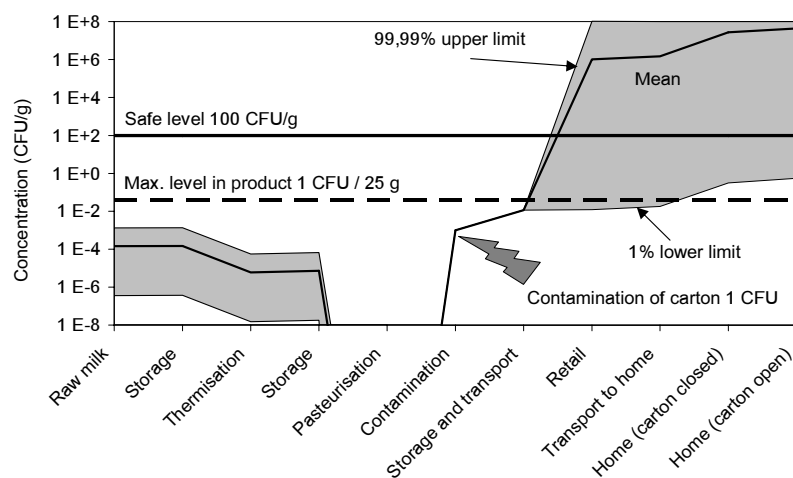

Figure 2: Mean and confidence limits of the probability density function of predicted concentrations of *Listeria monocytogenes* from milk delivery to consumption, assuming a milk carton is contaminated with 1 CFU of *Listeria* during production.

Growth and inactivation of L. monocytogenes during production of yogurt

If the fermentation tank (10.000 litre) is contaminated with 1 CFU of *L. monocytogenes*, the growth rate of *Listeria monocytogenes* during the first 12 hours of fermentation (when pH is higher than the minimum of 4.4) results in a probability of 70% that the concentration is higher than the maximum level for the product (1 per 25 ml). The probability that the concentration is higher than the safe level of 100 CFU/g is too low to calculate, however. *L. monocytogenes* does not grow at the yoghurt pH of 4 (Te Giffel and Zwietering, 1999), but the bacteria will survive.

Contamination event probabilities

For pasteurised milk and, to a much lesser degree, yoghurt, the probability of contamination during production is essential to the probability of complying with maximum levels (1 CFU/25 ml and 100 CFU/ml). Fault tree analysis of malfunction of pasteurisation (example tree in Figure 3) is used to estimate the probability of these top events by combining the probabilities of the base events causing the malfunction. Collecting data on base event PDFs, either from manufacturers or from failure log books, is the major difficulty in this process. Neither top event PDFs nor base event PDFs are to be made public, but a preliminary analysis has shown that the probability of pasteurisation malfunction occurring is so much lower than any feasible frequency of product quality monitoring that the added value of verification monitoring in risk management may become questionable.

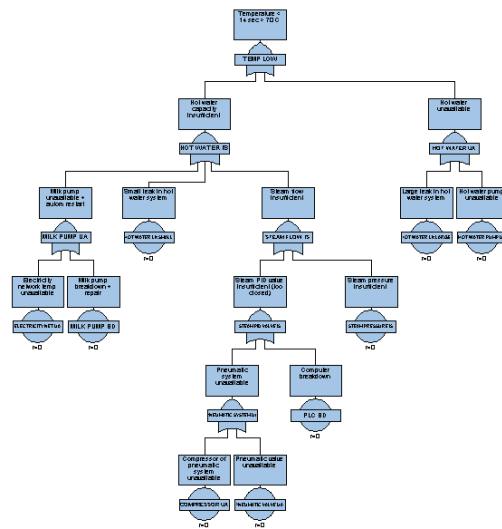

Figure 3: Example of the structure of a fault tree, in this case of a simple Pasteurizer.

Conclusions

The results of this study form the base of a quantitative framework that will facilitate quality managers in the dairy chain in their decisions to balance quality and costs in risk management and to prioritise the need for further risk assessments.

The modelling framework will initially be applied to indicate the necessity and priority of in-depth quantitative risk assessments (QRA) for specific dairy products. These first results will pin-point the sources of both the risk levels as well as the sources of uncertainty and variability, improving the quality of decisions regarding priorities in i) risk management efforts to decrease risks, ii) monitoring programs for the purpose of risk verification and iii) risk assessment research to decrease uncertainty.

Depending on the combination of the type of product and the type of contamination, the fine-tuning of the results either is focussed on the kinetic, stochastic or fault tree part. All product-contamination combinations will be modelled using readily available data and models, resulting in a priority list for optimisation of risk assessment and risk management.

References

- Davey K.R., Hall R.F. and Thomas C.J. (1995) Experimental and model studies of the combined effect of temperature and pH on the thermal sterilization of vegetative bacteria in liquid. *Food and Bioprocess Technology* 73, 127-132.
- De Jong P., Verschueren Vissers, M.M.M., Straatsma J. and Smit F. (2002) Hybrid modelling for development and optimisation of food production chains including costs and food quality. In: O'Connor, B. and Thiel, D. (editors) *2nd International Conference on Simulation in Food and Bio Industries*. Ghent. ISBN 90-77039-08-2 SCS Europe; b 13-17 pp.
- European Food Safety Authority (2006) The Community Summary Report on Trends and Sources of Zoonoses, Zoonotic Agents, Antimicrobial Resistance and Foodborne Outbreaks in the European Union in 2005. *The EFSA Journal* 94.
- Laguette O., Derens E. and Palagos B. (2002) Study of domestic refrigerator temperature and analysis of factors affecting temperature: a French survey. *International Journal of Refrigeration* 25, 653-659.
- Te Giffel M. and Zwietering M.H. (1999) Validation of predictive models describing the growth of *Listeria monocytogenes*. *International Journal of Food Microbiology* 46, 135-149.
- Vesely W.E., Goldberg F.F., Roberts N.H. and Vaas D.F. (1981) *Fault Tree Handbook*. NUREG-0492, US Nuclear Regulatory Commission.
- World Health Organisation and Food and Agricultural Organisation (2004) *Risk assessment of Listeria monocytogenes in ready-to-eat foods*. WHO, FAO, Geneva.
- Zwietering M.H., De Wit J.C. and Notermans S. Application of predictive microbiology to estimate the number of *Bacillus cereus* in pasteurised milk at the point of consumption. *International Journal of Food Microbiology* 30 (1-2), 55-70.